

Cooling Experts Around the Globe



AKG TUBE FIN FRAMELESS PRODUCT LINE

TubeFin Radiator

TubeFin Charge Air Cooler

LightWeight Cooler



AKG Group



AKG is a trusted partner and global leader for custom cooling solutions. For **100 years**, AKG has gained a wide-range experience through diverse customer needs and adapting to the growing demands of custom cooling solutions in various markets and applications.

AKG TubeFin Frameless Product Line

AKG's TubeFin Frameless Product Line Coolers are the new products developed based on the growing demands from the market and the active feedback from our customers. Our coolers find a common place in On & Off highway vehicles such as

- Wheel loaders
- Excavators
- Tractors
- Telehandler
- Combines
- Harvesters
- Gensets
- Specialty Trucks

This **Product Line** offers customer specific cooler design with

- Customizable modules
- LightWeight frameless design
- Low tooling cost
- Extended durability

The **Product Line** includes

- *TubeFin Radiator for coolant*
- *TubeFin Charge Air Cooler for turbocharged air*
- *LightWeight Cooler for oil and fuel*

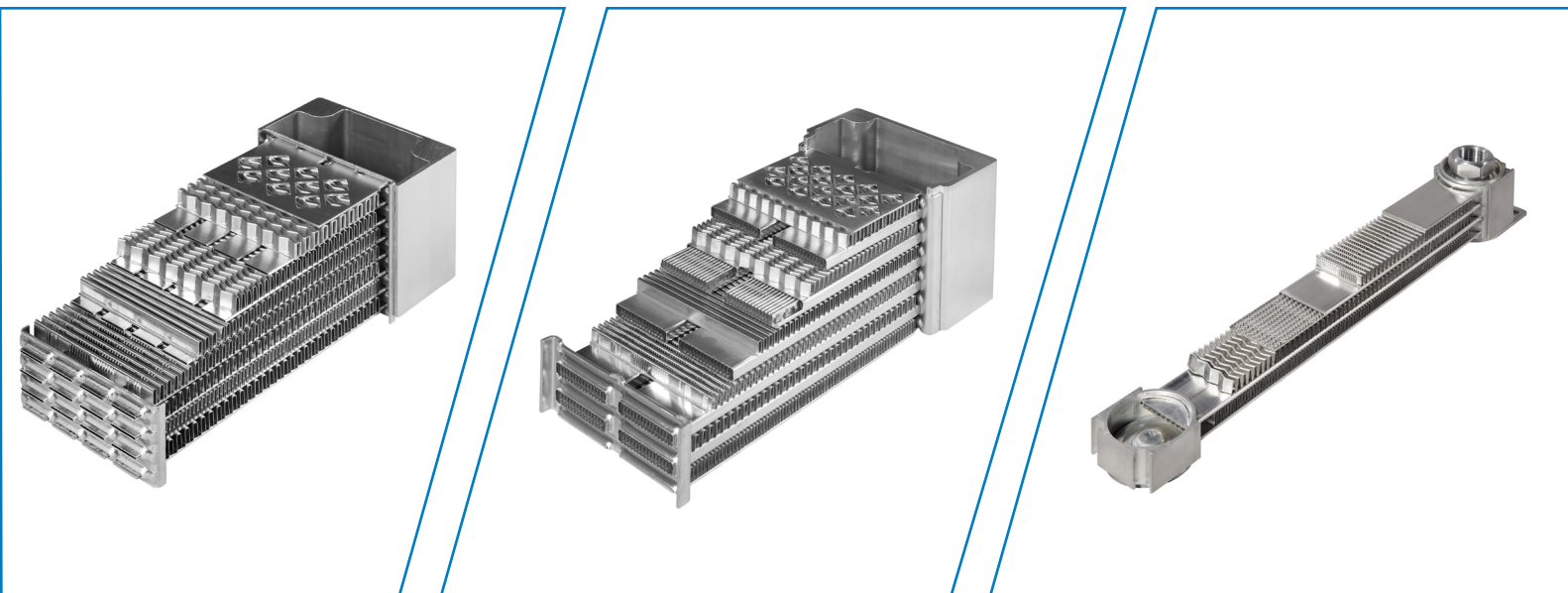

AKG TubeFin Frameless Product Line

AKG's cooling solutions are highly customizable matching our customer's demands with application specific requirements

- AKG cooling solutions are highly cost efficient
- The customer receives a tailor-made solution
- Available with extruded and casted tanks

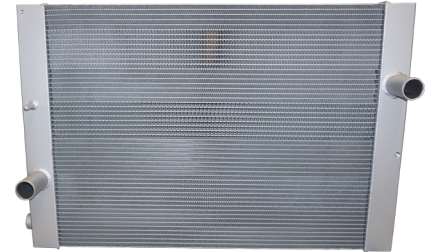

AKG's TubeFin Frameless Product Line can be combined side-by-side with AKG bar/plate coolers or assembled face-to-face into a cooling package

- Low tooling cost making it the ideal solutions for small to large volume / batch sizes
- Customers can buy a fully optimized and integrated powerful modular cooling package to cover all different cooling needs

AKG's TubeFin Frameless Product Line allows choice of multiple air fins; full range, from high performance fins to rugged environment fins

- High performance wavy fins with different pitch and sizes
- Wavy fin ensures better air flow and provides larger surface for heat exchange
- Variety of choices of products at no extra costs

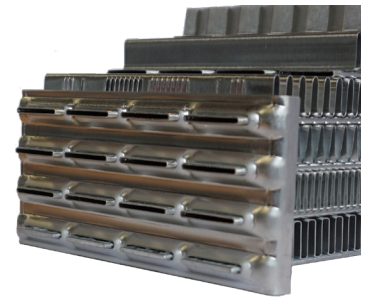

Structurally the cooler assemblies are strong enough to even be used as mounts for small assembly parts

- The cooling package is lightweight and robust in nature
- Frameless and rugged design for demanding applications
- Connections like beaded tube, threaded connections can be modified flexibly
- Full integration generates high efficiency

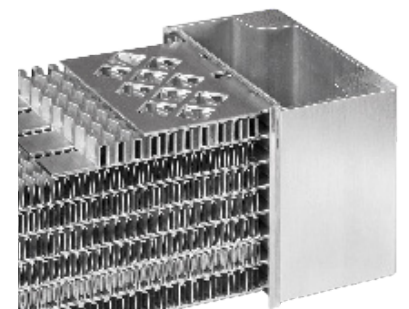

Extended durability with long life materials

- The long life materials are produced by modifying the standard materials and its alloying elements
- This results in high mechanical, thermal and corrosion resistance
- The fins, turbulators and other cooler related parts are produced from long life materials



TubeFin Radiator

The AKG TubeFin Radiator fits applications that require lightweight construction and high cooling performance. The lightweight and robust design eliminates the usage of steel parts, hence the frameless name. The coolers are available with wide variety of core thickness, fin styles, and production quantities.

The latest updates of AKG TubeFin Radiator use long-life materials for extended durability. The sideplate's unique DIAMOND CUT feature accommodates thermal expansion and increases the lifetime of the cooler.

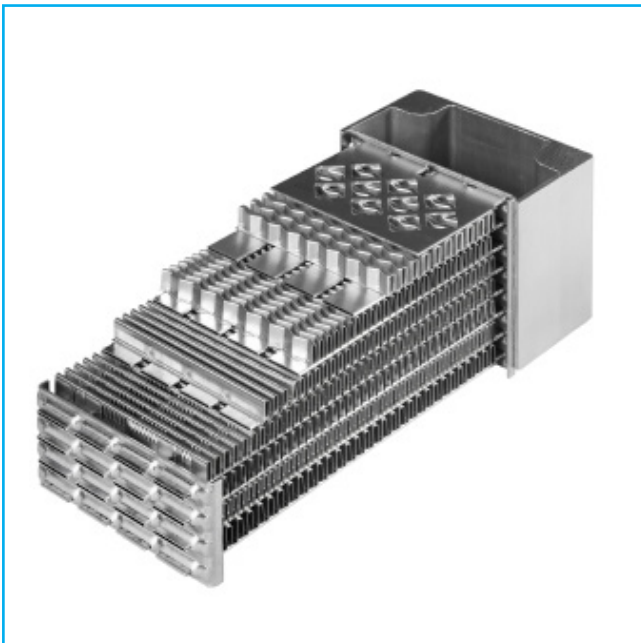

Technical Specifications

- Temperature Range: - 40 °C to 120 °C
- Working pressure: Std. 2 bar (upto 5 bar)
- Cooling medium: Coolant

Core Size & Dimension

- Depth - 94 / 118 / 140 mm
- Length - upto 1500 mm
- Height - upto 1000 mm

Benefits of AKG TubeFin Frameless Product Line General

Lightweight, rugged engine cooling solution at low cost

Diamond cut side plate for high durability at thermal stresses

Compatible with bar/plate in side-by-side arrangements

Available with extruded and casted tanks

TubeFin Charge Air Cooler

The AKG TubeFin Charge Air Cooler is a special construction where the turbulators are integrated into the tubes for an unique design. The new design is lightweight in construction and there are possibilities to produce in different lot sizes with minimal tooling cost. It is available with competitive prices and a great cooling performance.

The usage of extruded aluminium header tanks and casting tanks is possible with the new design. The modular concept design enables us to assemble the cooler in different configurations (Side-by-side and Face-to-Face).

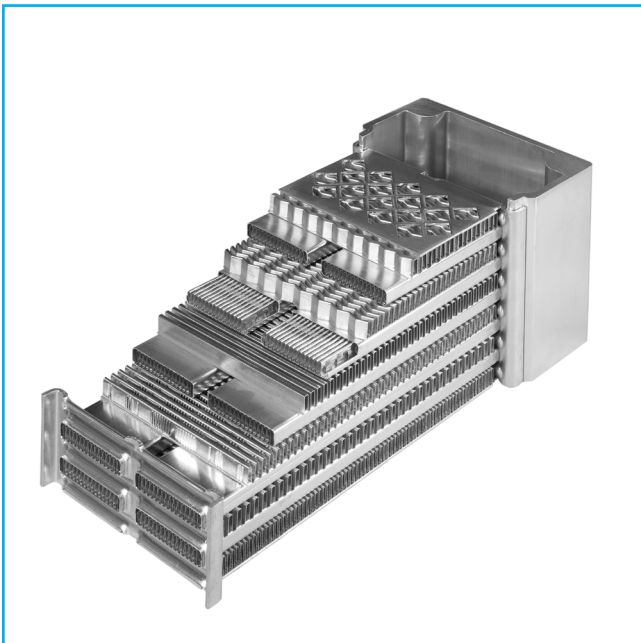

Technical Specifications

- Temperature Range: - 40 °C to 230 °C
- Working pressure: Std. 3 bar (upto 5 bar)
- Cooling medium: Charge Air

Core Size & Dimension

- Depth - 63 / 94 / 113 / 140 mm
- Length - upto 1500 mm
- Height - upto 700 mm

Extended durability with longlife materials

Adaptable to application specific requirements

Available in small batch with minimal tooling cost

Many possibilities to create customized variants

LightWeight Cooler

LightWeight cooler construction is unique among cooler types. The entire cooler is completely brazed as one single unit with no welding. This enables a shorter lead-time for our customer. The cooler is lightweight and robust, making it suitable for oil cooling in hydraulic, transmission, and fuel systems. Varieties of threaded connections are possible.



Technical Specifications

- Temperature Range: - 40 °C to 150 °C
- Working pressure: upto 16 bar
- Cooling medium: Oil, Fuel (Coolant & Air)

Core Size & Dimension

- Depth - 45 mm
- Length - upto 800 mm
- Height - upto 500 mm

Benefits of LightWeight Coolers

Lightweight, rugged engine cooling solution at low cost

Available in different lot sizes due to low tooling cost

Low lead time as the cooler is brazed as one single part

Extended durability with long life materials

AKG TubeFin Frameless Product Line





AKG Thermotechnik International GmbH & Co. KG

Am Hohlen Weg 31
D-34369 Hofgeismar • Germany
Phone + 49 5671 - 8 83 - 0

info@akg-group.com

www.akg-group.com



AKG GROUP – A STRONG GLOBALLY REPRESENTED COMPANY

AKG is a leading global supplier of high-performance coolers and heat exchangers, providing custom system solutions with the highest quality standards.

Around the world 2,750 employees work at 11 manufacturing facilities located in Germany, France, Latvia, Turkey, the USA, Brazil, China and India. Together with a number of sales offices in additional countries and regions, AKG's cooling experts are on duty around the clock.

Longstanding partnerships with global OEM customers from 24 lines of business - including construction machinery, compressed air systems, agricultural and forestry machines, and many others - give fresh and innovative inspiration for AKG's line of pre-engineered cooling systems as well.

AKG operates one of the world's largest research, development, measurement and validation centres for cooling solutions and customized applications.

For over 100 years, AKG's heat exchangers have stood for innovative solutions as well as the highest standard of engineering and manufacturing expertise.